



**SPP**

*Southwest  
Power Pool*

***Facility Study  
For  
Generation Interconnection  
Request  
GEN-2010-052***

***SPP Generation  
Interconnection***

***(#GEN-2010-052)***

***July 2011***

## Summary

Xcel Energy Inc. (Xcel) performed a detailed Facility Study at the request of Southwest Power Pool (SPP) for Generation Interconnection request GEN-2010-052. The request for interconnection was placed with SPP in accordance with SPP's Open Access Transmission Tariff, which covers new generation interconnections on SPP's transmission system.

## Interconnection Customer Interconnection Facilities

The Interconnection Customer will be responsible for the 345 kV transmission line from its wind turbine Collector Substation to the Point of Interconnection (POI), the Finney 345kV substation located in Finney County, Kansas. In addition, the customer will be responsible for reactive power compensation equipment to maintain 95% lagging (providing vars) and 95% leading (absorbing vars) power factor at the point of interconnection.

## Transmission Owner Interconnection Facilities and Non-Shared Network Upgrades

Per the following Facility Study, the Interconnection Customer is responsible for **\$6,766,756** of Transmission Owner Interconnection Facilities and non-shared network upgrades.

## Shared Network Upgrades

The interconnection customer was studied within the DISIS-2010-002 Impact Restudy. At this time, the Interconnection Customer is allocated the following cost for shared network upgrades:

Upgrade Description	Allocated Cost	Total Cost
Beaver County – Gray County 345kV. Build 345kV transmission line between Beaver County and Kansas State Line. Includes substation work at Beaver County. (Construction by OG&E)	\$18,112,785	\$105,609,050
Beaver County – Gray County 345kV. Build 48 miles of 345kV transmission line between Gray County and Oklahoma State Line. Includes construction of additional 345kV line terminal with reactor at Gray County. (Construction by Sunflower)	\$11,079,409	\$64,600,000
<b>Total</b>	<b>\$29,192,194</b>	

If higher queued interconnection customers withdraw from the queue, suspend or terminate their GIA, restudies will have to be conducted to determine the Interconnection Customers' allocation of shared network upgrades. All studies have been conducted on the basis of higher queued interconnection requests and the upgrades associated with those higher queued interconnection requests being placed in service.

### **Additional Required Network Upgrades**

Certain Network Upgrades that are not the cost responsibility of the Customer are required for Interconnection. These Network Upgrades include:

1. Hitchland - Woodward 345kV double circuit transmission line,
2. Medicine Lodge - Woodward 345kV double circuit transmission line,
3. Medicine Lodge - Wichita 345kV double circuit transmission line
4. Tuco – Woodward 345kV transmission line.

These network upgrades are not schedule to be in service until December 31, 2014. Depending upon the status of higher or equally queued customers, the Interconnection Customer's in service date may be delayed until the in service date of these Network Upgrades.

Additionally, the following network upgrade is the responsibility of a higher queued project. If due to the withdrawal of any higher queued project, the Interconnection Customer may be responsible for the cost of the following.

1. Finney – Holcomb 345kV ckt #2. – Build a second 345kV line from Finney to Holcomb and associated 345kV substation work at both ends.



**Facilities Study For**  
301.3 MW Wind-Generated Energy Facility  
Finney County, Kansas  
SPP #GEN-2010-052

July 13, 2011

Xcel Energy Services, Inc.  
Transmission Planning

## Executive Summary

("Interconnection Customer") in 2010 requested the interconnection of a wind energy facility located in Grant County, Kansas to the Southwestern Public Service Company (SPS) transmission network. SPS is a New Mexico Corporation and wholly owned subsidiary of Xcel Energy Inc. This facility has a net capacity of 301.3 MW. The Interconnection Customer's facility will connect at Finney Switching Station located in Finney County, Kansas approximately seven (7) miles southwest of Garden City, Kansas. The Interconnection Customer's expected commercial operation date and back-feed date is December 31, 2012 and September 15, 2012 respectively.

The Southwest Power Pool (SPP) evaluated the request to interconnect the wind farm facility to the SPS transmission system in Definitive Interconnection System Impact Study (DISIS-2010-002) GEN-2010-052 completed in January 2011. The interconnection request was studied using one-hundred-thirty-one (131) Siemens SWT wind turbines at 2.3 MW each for a total output of 301.3 MW and the interconnection customer will have one (1) 348 MVA 345/34.5 kV transformers. The Interconnection Customer is required to maintain a Power Factor of 0.95 lagging and 0.95 leading at the point of interconnection.

SPS requires that all construction for this request be in compliance with the latest revision of the Xcel Energy Interconnection Guidelines for Transmission Interconnection Producer-Owned Generation Greater than 20 MW, is available at:

[http://www.xcelenergy.com/Energy\\_Partners/Generation\\_Owners/Interconnection\\_Guidelines/Interconnection\\_Guidelines\\_For\\_Customer-Owned\\_Generation\\_-\\_South](http://www.xcelenergy.com/Energy_Partners/Generation_Owners/Interconnection_Guidelines/Interconnection_Guidelines_For_Customer-Owned_Generation_-_South) . This document describes the requirements for connecting new generation to the Xcel Energy transmission systems including technical, protection, commissioning, operation, and maintenance. SPS will also require that the Interconnection Customer be in compliance with all applicable criteria, guidelines, standards, requirements, regulations, and procedures issued by the North American Electric Reliability Corporation (NERC), Southwest Power Pool (SPP), and the Federal Energy Regulatory Commission (FERC) or their successor organizations.

The Interconnection Customer is responsible for the cost of the Interconnection Facilities, installation of necessary capacitor banks and any Direct Assigned Interconnection Facilities; inclusive of all construction required for the 345 kV transmission line from the Interconnection Customer's substation to the SPS Finney Switching Station.

A reactor may be needed to keep the power factor at the point of interconnect between 0.95 lagging to 0.95 leading, during low energy output conditions. The Interconnection Customer is responsible for the cost and installation of shunt reactive power compensation (a 345 kV line reactor of 25 MVAR). A cost estimate for the 25 MVAR reactor and 345 kV breaker is provided, but customer must provide the reactor and it should be switched by a 345 kV breaker, if used. See one line diagram on page 11.

As for this request GEN-2010-052, it is anticipated that the entire process of adding the new 345 kV line terminal at Finney Switching Station for the acceptance of the wind farm facility output will require approximately 16 months to complete after an Interconnection Agreement is signed and an authorization to proceed is received.

The cost of these upgrades, inclusive of the Interconnection Customer's cost for the interconnection of this wind farm facility, is shown below in Table 1, with the detailed description of the cost shown in Table 3.

**Table 1, Cost Summary, Finney Switching Station**

<b>SPS Network Upgrades:</b>	<b>\$ 3,568,356</b>
<b>Interconnection Facilities <sup>1</sup>:</b>	<b>\$ 3,198,400</b>
<b>Total:</b>	<b>\$ 6,766,756</b>

---

<sup>1</sup> This is a direct assigned cost to the Interconnection Customer.

## General Description of SPS Facilities<sup>2</sup>

1. **Construction of New Line Terminal:** See Figure A- 1 Appendix A, for general vicinity location map.
  - 1.1. **Location:** SPS will add a new 345 kV line terminal, which includes four (4) new 345 kV breakers at the existing SPS Finney Switching Station. Appendix A, Figure A-2 shows the one-line of the Switching Station, while Appendix A, Figure A-3 shows the preliminary elevation plan view of the Station.
  - 1.2. **Bus Design:** The existing 345 kV ring-bus at Finney Switching Station will be expanded to breaker and half configuration for the new 345 kV line terminal to accommodate the output from the wind energy facility. This design is shown in the one-line in Appendix A, Figure A-2.
  - 1.3. **Line Terminals:** The conductor will be pulled in at full tension. The substation dead end structures must be capable of 14,000 pounds per conductor (28,000 per bundle). The maximum static tension to be considered is 7,000 pounds per static wire. The dead end towers must be designed for a 15° pull-off angle.
  - 1.4. **Control House:** The existing control house will be utilized to accommodate the new metering, protective relaying and control devices, terminal cabinets, and any fiber-optic cable terminations, etc. for the new 345 kV line breaker terminal.
  - 1.5. **Security Fence:** The existing security fence shall be extended if required when the new branch is added for the new 345 kV line terminal.
  - 1.6. **Ground Grid:** The existing ground grid shall be extended to accommodate the additional bay required for the new line terminal per ANSI/IEEE STD 80-1986, with our standard 4/0 copper ground mesh on 40-foot centers with ground rods and 20-foot centers in corners and loop outside of fence.
  - 1.7. **Site Grading:** Company contractor, per company specifications, will perform any site grading and erosion control to accommodate the new line terminal. Soil compaction shall be not less than 95% of laboratory density as determined by ASTM-D-698.
  - 1.8. **Station Power:** The existing switching station power, provided from the local distribution system, will be utilized.
  - 1.9. **Relay and Protection Scheme:** The new 345 kV breaker line terminal primary protections to the interconnection customer 345 kV transmission line will use line current differential relaying over optical fiber installed in the static of the customer's 345 kV transmission line. The use of fiber is necessary to provide dual high-speed communications assisted tripping schemes plus direct transfer trip both ways in the event of breaker failures (a SPS design standard). Secondary relaying will use mirrored bit, Permissive Overreaching Transfer Trip (POTT) over the optical fiber. An SEL 311L and a 421 will be used as primary and secondary relays, respectively. No automatic re-closing scheme will be used. The SEL

---

<sup>2</sup> All modifications to SPS facilities will be owned, maintained and operated by SPS.

421 will be used for line/bus SCADA closing conditions for the 345 kV breakers. A SEL 501-0 will be used for breaker failure.

An SEL DTA-2 or other SCADA capable devices will display the bus voltage, GCB amps, MW, MVAR, and fault location.

- 1.10. **Revenue Metering:** On the existing SPS Finney Switching Station 345 kV line terminal at the Customer's Point of Interconnection (POI) to the Customer's switching station, an individual billing meter will be installed along with a meter per, ANSI C12.1 accuracy class 0.2 (3-PT's IEEE C57.13 accuracy class 0.3 and 3 CT's IEEE C57.13 accuracy class 0.15) for full 3-phase 4-wire metering. Also installed for the metering units will be optical 3-PT's and 3-CT's for full 3-phase 4-wire metering. There will be two meters per line terminal: one will be primary and the other will be back up, each will have full 4 quadrant metering. Pulses out of the primary billing meter will be sent via SCADA to the Transmission Owner's Control Center in Amarillo, Texas.
- 1.11. **Disturbance Monitoring Device:** Disturbance Fault Recorder (DFR), capable of recording faults, swings, and long term trending, will be installed to monitor and record conditions in the substation and on the transmission lines. The disturbance equipment shall also be equipped with a GPS time synch clock. This equipment will have communication capability with a dedicated communication circuit. The disturbance equipment will have its own dedicated dial-up communications telephone circuit.
- 1.12. **Remote Terminal Unit (RTU):** The existing RTU will be utilized to accommodate the new 345 kV line terminals at Finney Switching Station. SPS will provide and install if needed additional RTU cards for metering and telemetry as required by the latest Xcel Energy Interconnection Guidelines. The direct cost will be charged to the Interconnection Customer.
- 1.13. **Communications:** Existing telephone and data circuit at Finney Switching Station to the Amarillo Control Center will be utilized. ***It is the Interconnection Customer's responsibility to make arrangements with the local phone company to provide telephone circuits to the relay communication equipment and disturbance-monitoring equipment at Finney Switching Station and to their wind farm facility. Prior to any construction the Interconnection Customer is required to contact the SPS substation-engineering department for all details.***

A schematic outlining the proposed communications is provided below:



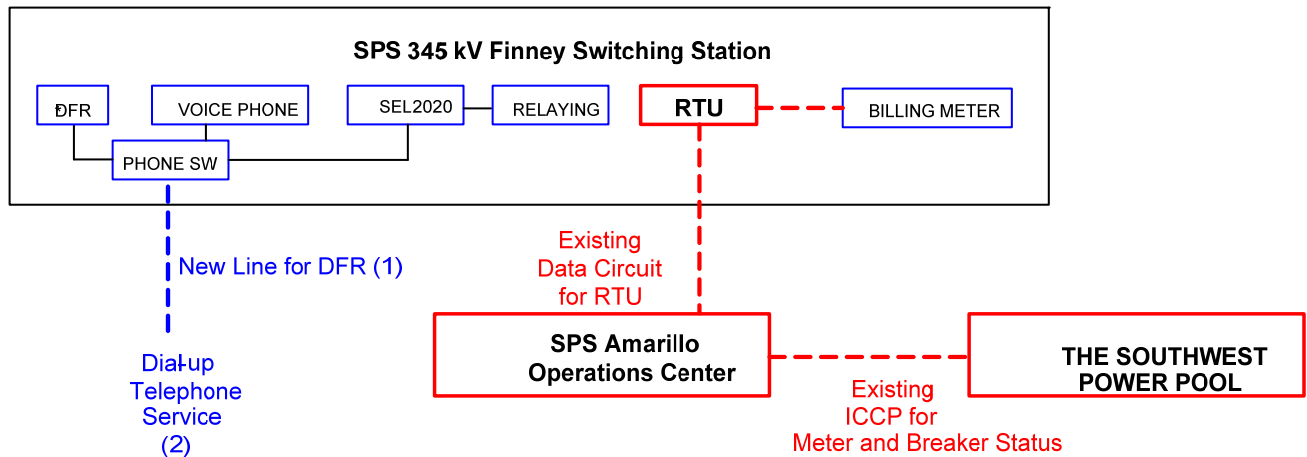

The Interconnection Customer shall be responsible for providing fiber optic communication circuit installed in their overhead transmission line static wire, as indicated in Section 1.9, from the customer's switching station to Finney Switching Station control house. Also customer will be responsible for additional communication relays required at Finney Switching Station the new wind farm terminal to interrogate protective relays mentioned in Section 1.9.

## 2. Transmission Work:

- 2.1. The Interconnection Customer will construct, own, operate, and maintain the 345 kV transmission line from the Interconnection Customer's switching station to the Interconnection Point at SPS Finney Switching Station as shown in Appendix A, Figure A-2. ***The SPS transmission design group prior to any construction by the Interconnection Customer or its contractor on any customer 345 kV transmission lines, or doing work in close proximity to any SPS transmission line, will require an engineering review of the customer's design. It is the Interconnection Customer's responsibility to initiate the design review in a timely manner before construction of any transmission line begins. If the review has not been made or the design at any of the aforementioned locations is deemed inadequate, the crossing(s) and or termination into the SPS Finney Switching Station will be delayed until the matters are resolved. SPS will not be held responsible for these delays.***

## 3. Right-Of-Way and Permits:

- 3.1. **Permitting:** The Kansas Public Utility Commission will not require a permit for the construction of a new 345 kV line terminal to receive output from the Customer's wind farm facility at Finney Switching Station. The interconnection customer will be responsible for any permitting and right of way of their substation, switching station, the 345 kV transmission lines from their collector substation to the Point of Interconnection at Finney Switching Station.

4. **Construction Power and Distribution Service:** It is the sole responsibility of the Interconnection Customer to make arrangements for both construction and station power, which may be required for the Interconnection Customer's wind farm facility. **Additionally, if the Interconnection Customer's substation(s) and/or construction site(s) are located outside of the SPS service**

area, SPS cannot provide station power (retail distribution service) and the Interconnection Customer needs to make arrangements for distribution service from the local retail provider.

**5. Project and Operating Concerns:**

5.1 Close work between the Transmission group, the Interconnection Customer’s personnel and local operating groups will be imperative in order to meet any in-service date that has been established.

5.2 It is understood that the Capacitor Banks will be installed at the Interconnection Customer’s substation on the 34.5 kV bus side to avoid voltage spikes on the 345 kV that adversely affects the Xcel Energy transmission system. The Interconnection customer will be required to maintain a Power Factor of 0.95 lagging and 0.95 leading at the Point of Interconnection (POI) and switch the capacitor banks in stages of 20 MVar or less. This is required to maintain acceptable dynamic voltage rise as per latest revision of the Xcel Energy Interconnection Guidelines for Transmission Interconnection Producer-Owned Generation Greater than 20 MW, is available at:  
[http://www.xcelenergy.com/About\\_Us/Transmission/About\\_Transmission/Interconnections](http://www.xcelenergy.com/About_Us/Transmission/About_Transmission/Interconnections)

6. **Fault Current Study:** The available fault current at the interconnection location, without any contribution from the wind farm facilities, is shown in Table 2 below.

**Table 2, - Available fault current at Point of Interconnection Location**

<b>Short Circuit Current Availability at Finney Switching Station without contribution from GEN 2010-052</b>				
Fault Location	Fault Current (Amps)		Impedance ( $\Omega$ )	
	Line-to-Ground	3-Phase	$Z^+$	$Z^0$
345 kV Bus	6,401	5,628	$2.369+j35.313$	$1.570+j22.513$

<b>Short Circuit Current Availability at Finney Switching Station without contribution from GEN 2010-052 But with the addition of all the Proposed Infrastructure Transmission Lines by SPP</b>				
Fault Location	Fault Current (Amps)		Impedance ( $\Omega$ )	
	Line-to-Ground	3-Phase	$Z^+$	$Z^0$
345 kV Bus	Not Available	9,461 @-114°	Not Available	Not Available

## Estimated Construction Costs

The projects required for the interconnection of this 301.3 MW Wind Farm facility consist of the projects summarized in the table below.

**Table 3, Required Interconnection Projects<sup>3</sup>**

<b>Project</b>	<b>Description</b>	<b>Estimate</b>
	<b>SPS Network Upgrades</b>	
1	4-New 345 kV Breakers and Line Terminal	\$ 3,517,010
2	Disturbance Monitoring Device	\$ 51,346
	<b>Subtotal:</b>	<b>\$ 3,568,356</b>
<hr/>		
	<b>Interconnection Facilities (at the Interconnection Customer's expense)</b>	
3	Communications <sup>4</sup>	\$ See footnote
4	345 kV Disconnect Switch	\$ 45,305
5	Remote Terminal Unit (RTU)	\$ 10,000
6	Revenue metering	\$ 225,000
7	345 kV Line arrestors	\$ 12,743
8	25 MVAR Reactor and 345 kV Breaker installed on Customers Facilities if NEEDED	\$ 2,905,352
	<b>Subtotal:</b>	<b>\$ 3,198,400</b>
	<b>Total Cost:</b>	<b>\$ 6,766,756</b>

## Engineering and Construction:

An engineering and construction schedule for the installation of the 345 kV line terminals is estimated at approximately 16 months. Other factors associated with clearances, equipment delays and work schedules could cause additional delays. The schedule is applicable after all required agreements are signed, CCN's issued and internal approvals are granted.

All additional cost for work not identified in this study is the sole responsibility of the Interconnection Customer unless other arrangements are made.

<sup>3</sup> The cost estimates are 2011 dollars with an accuracy level of  $\pm 20\%$  except as noted, with AFUDC added.

<sup>4</sup> If needed, it is the Requester's responsibility to provide both the data circuit and both dial-up telephone circuits, see Section 1.13.

## Appendix A



Figure A- 1 Approximate location of proposed Wind Farm Facility

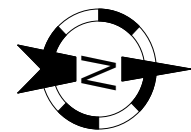
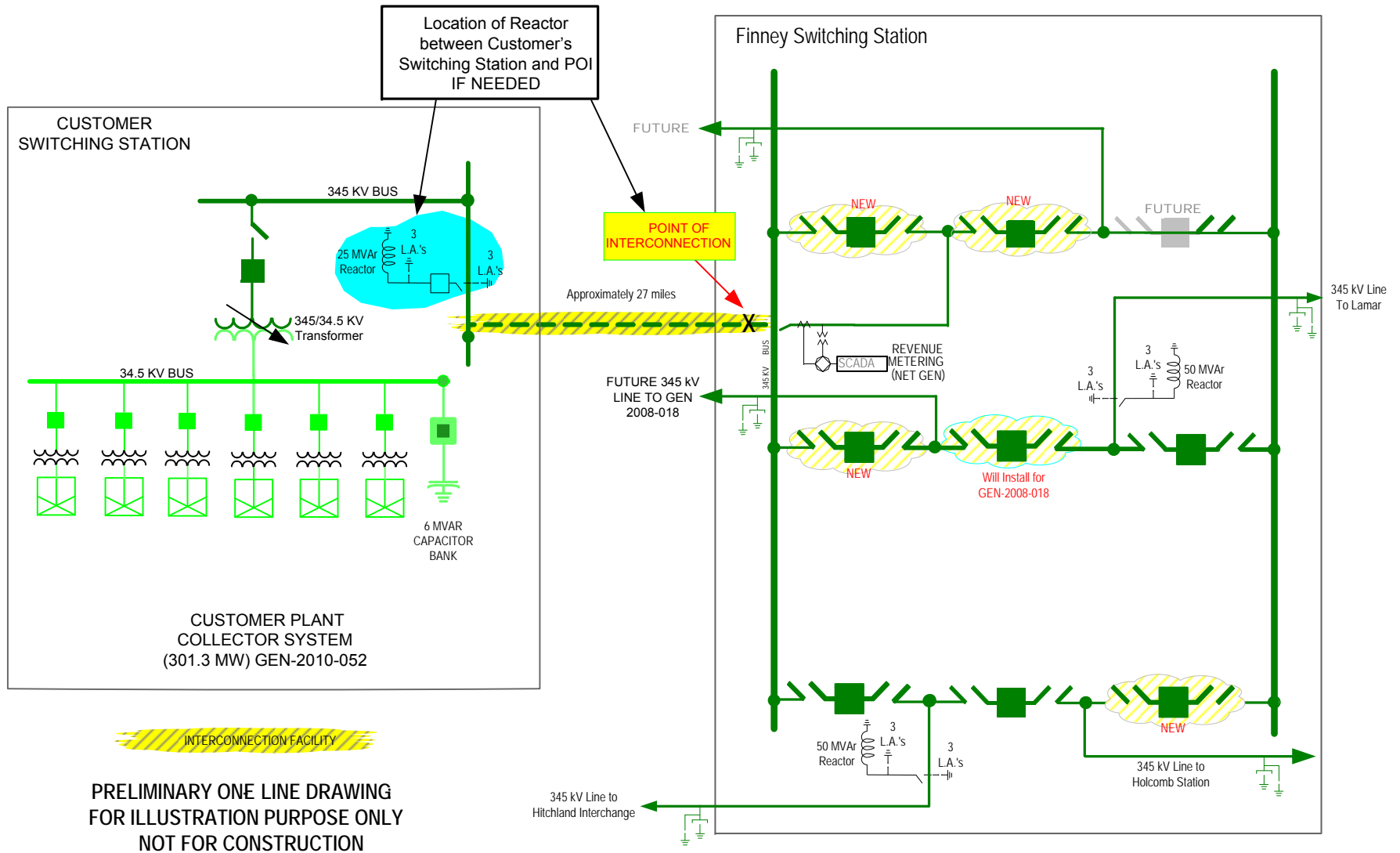
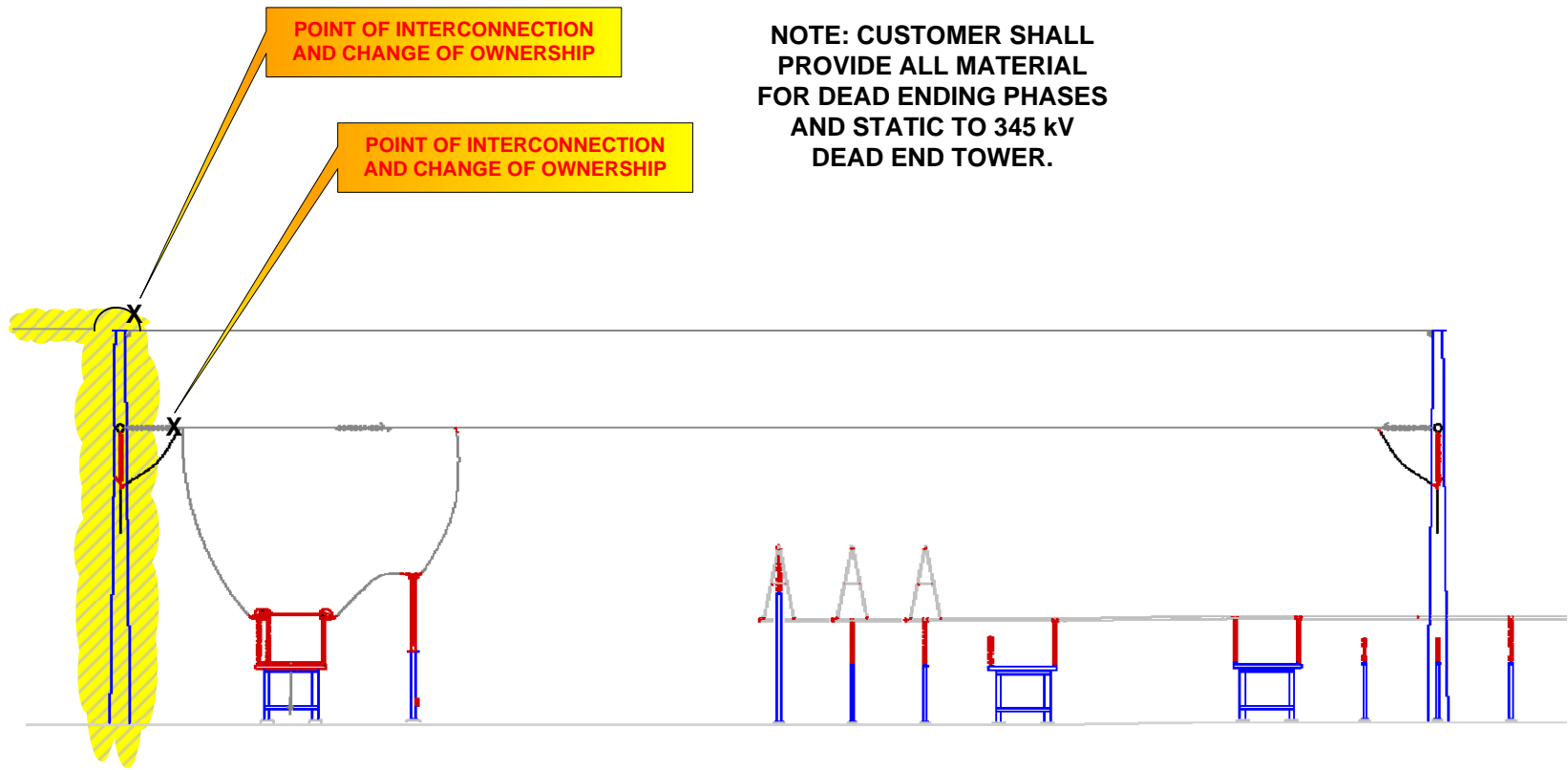

Figure A- 2 One-line Diagram of Finney Switching Station to Customer Interconnection Facility



**NOTE: CUSTOMER SHALL PROVIDE ALL MATERIAL FOR DEAD ENDING PHASES AND STATIC TO 345 kV DEAD END TOWER.**

**THIS DRAWING ILLUSTRATES ONLY THE POINT OF INTERCONNECTION AND THE BOUNDARIES OF CUSTOMERS RESPONSIBILITY. IT MAY NOT BE USED FOR CONSTRUCTION**

Customer's Responsibility

**Figure A- 3 Point of Interconnection & Change of Ownership (Typical)**

*– END OF REPORT –*